

DALI PRO 2 IoT



WebUI User Instruction

DALI PRO 2 IoT WebUI User Guide

This user guide is designed to provide you with comprehensive instructions and insights into the usage and functionality of the DALI PRO 2 IoT WebUI. Whether you are a lighting professional, an installer, or a system administrator, this guide will assist you in navigating the features and capabilities of the DALI PRO 2 IoT.

The DALI PRO 2 IoT WebUI is a powerful, web-based, user interface that enables you to setup, commission, monitor, and manage your DALI PRO 2 IoT lighting installation. With its intuitive design and robust functionality, the WebUI empowers you to customize settings and streamline operations.

All information in this guide has been prepared with great care. INVENTRONICS, however, does not accept liability for possible errors, changes and/or omissions. Please check www.inventronics-light.com or contact your sales partner for an updated copy of this guide.

Table of contents

1. DALI PRO 2 IoT lighting controller	4
1.1 Overview	4
1.2 Installation	6
1.3 Wiring Diagram	6
1.4 On-Site Check	6
2. Log In to the DALI PRO 2 IoT Controller	7
2.1 Establishing a connection through the built-in web server.	7
2.2 Registration process	8
2.3 Log on	9
3. Controller Configuration	9
3.1 Project creation	10
3.2 Search for DALI devices	11
3.3 Template selection	12
3.4 Assigning of DALI devices	14
3.5 Upload a project	17
4. System Information	19
5. System settings	20
5.1 General tab	20
5.2 Network Settings	21
5.3 User Management	21
5.4 Advanced	22
5.5 Alerts and Reporting	23
6. Remote Access	25
7. Emergency Lighting	26
7.1 Commissioning	26
7.2 Configuring the EL test reports	27
7.3 EL report	27
7.4 Test configuration	29
7.5 Email configuration	29
8. Luminaire failure alerts	30
9. Notes	31
10. Technical Data	32

1. DALI PRO 2 IoT lighting controller

The DALI PRO 2 IoT controller is a feature-rich, two-channel DALI-2 controller. It boasts an intuitive browser-based graphical user interface for easy commissioning and comes with a built-in gateway that connects to the cloud, enabling IoT applications.

There are two methods for commissioning the DALI PRO 2 IoT controller: the first is through a Windows-based software, known as the PC Tool, which can be installed on your personal computer. You can find this tool available here: [Dali Pro 2 IoT - Inventronics \(inventronics-light.com\)](http://Dali_Pro_2_IoT_-_Inventronics_(inventronics-light.com)). The second method is via the WebUI, and this guide will cover the latter approach.

1.1 Overview

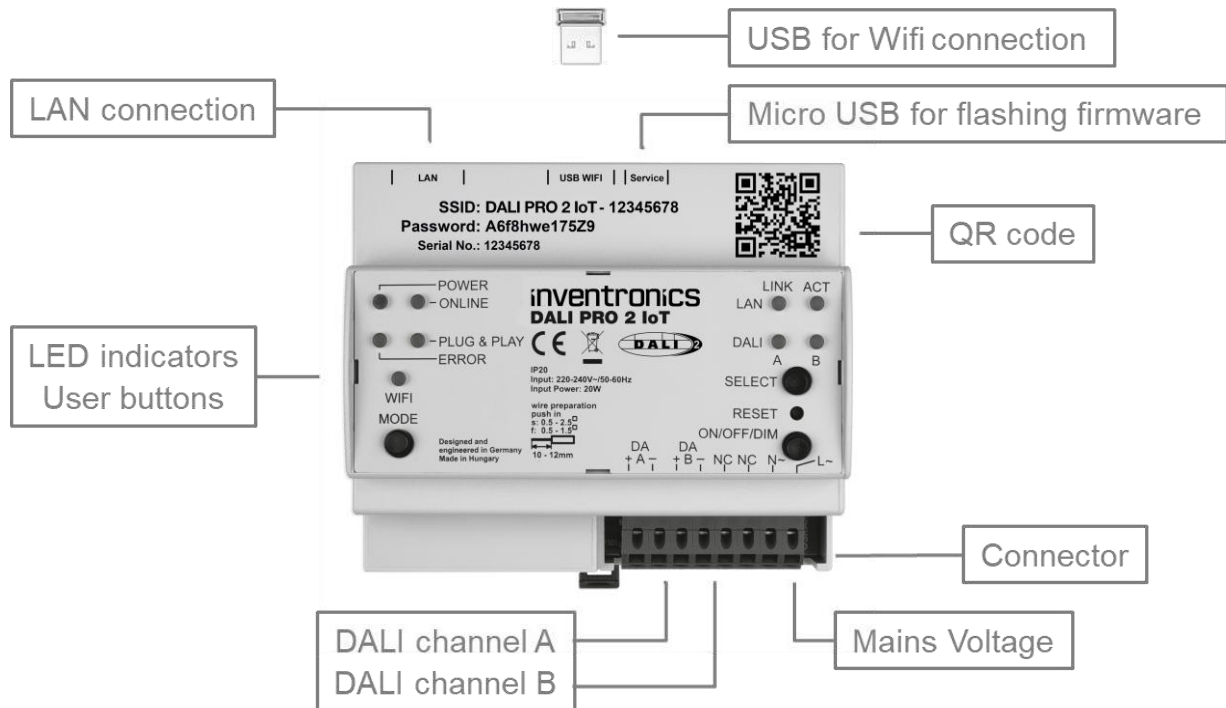

The USB Wi-Fi dongle is included in the package and must be inserted by the user.

The micro-USB connector is used for flashing firmware (for manufacturer use only)

The controller provides status information through colored **LED indicators** and allows users to configure settings using **User Buttons**

LED Indicators

User Buttons



LED indicators

POWER

LED = on mains voltage is present, controller is operational

ONLINE

LED = on controller is connected to the Inventronics cloud

WIFI

LED = on WIFI connection is activated

LED = flashing WIFI connection is being activated (booting)

LAN LINK

LED = flashing Indicates data traffic

LAN ACT

LED = on LAN is active

DALI A

LED = on DALI voltage is present

LED = flashing DALI line is too low, voltage = 0V

LED = sparking DALI line is too high, voltage > 20V

DALI B

LED = on DALI line voltage is present

LED = flashing DALI line is too low, voltage = 0V

LED = sparking DALI line is too high, voltage > 20V

PLUG & PLAY

LED = on Controller is not programmed yet, Plug & Play option available

ERROR

LED = on Error detected

User Buttons

MODE

switches on/off the Wi-Fi (toggle function)

SELECT

selects DALI channel "A" or DALI channel "B" or both (toggle function)

RESET

short press (min. 5 seconds) = a reset as in power cycle

long press (min. 15 seconds) = re-boot the system

ON/OFF/DIM

toggles through on-off-dim functions for the selected channel(s)

1.2 Installation

The DALI Pro 2 IoT controller is to be mounted on a 35 mm DIN rail inside a switch cabinet as per DIN 43880 requiring a width of 6 horizontal pitch units.

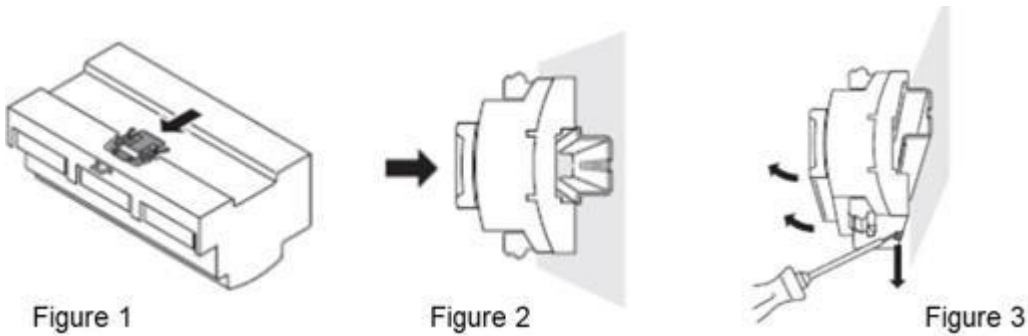

Mounting the controller on a DIN rail

Figure 1: press in the lock clip until you hear a click sound.

Figure 2: lock in the controller on the DIN rail.

Removing the controller from a DIN rail

Figure 3: push out the lock clip by using a screwdriver

1.3 Wiring Diagram

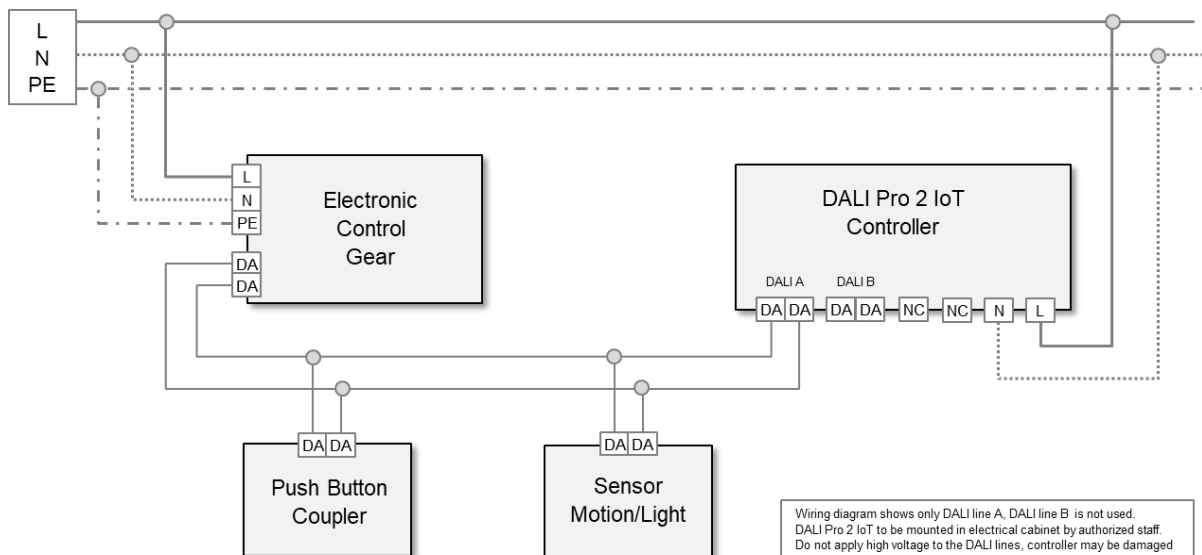

1.4 On-Site Check

When main voltage is applied, the controller's POWER LED will illuminate. Please allow for a 2-minute booting process for the internal micro-controller and Wi-Fi connection.

If the controller hasn't been programmed yet, the Plug & Play LED will activate, and you can test the functionality of the luminaires by toggling the ON/OFF/DIM button, which will broadcast the corresponding commands. Additionally, you can individually check channels A or B

2. Log In to the DALI PRO 2 IoT Controller

The USB Wi-Fi dongle (included) must be placed in the controller’s USB slot and activated by the MODE button. If activated, the Wi-Fi LED will light up. Wi-Fi mode will give the user access to the browser-based commissioning interface.

The information required to connect to the Wi-Fi network is printed on the controller:



2.1 Establishing a connection through the built-in web server.

When the WLAN dongle is inserted into the USB port of the DALI PRO 2 IoT Controller, you can activate its own WLAN network by performing a short press on the WIFI MODE button located on the device.

Once activated, the LED above the button will remain constantly lit, indicating that the WLAN network is now available for use. You can find this network listed among the available networks on your device. The network name (SSID) will start with "DALIPRO2-" and include the unique serial number of your DALI PRO 2 IoT Controller, which can be found printed on the device itself.

Please note that activating the DALI PRO 2 IoT Controller's WLAN network will temporarily disconnect your device from any previously connected Wi-Fi networks. You can reconnect to your previous Wi-Fi network once you have finished using the DALI PRO 2 IoT Controller's WLAN network.

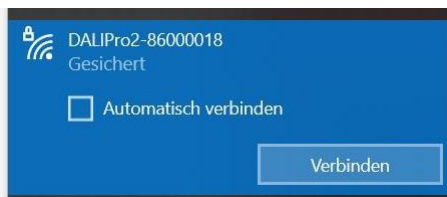

If you are prompted to enter a PIN, follow these steps to switch the input method:

On the screen where you are asked to enter the PIN, locate the option that says "Connect using a network security key".

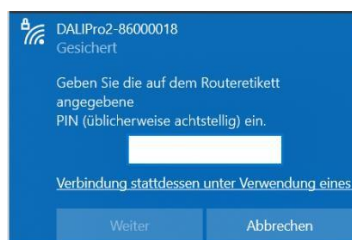

Enter the network security key or password printed on the controller

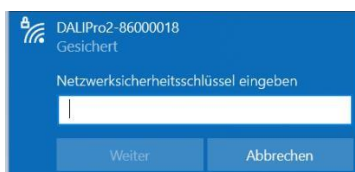

Please be aware that the WLAN network created by the DALI PRO 2 IoT Controller is intended for local use only and does not provide internet connectivity.

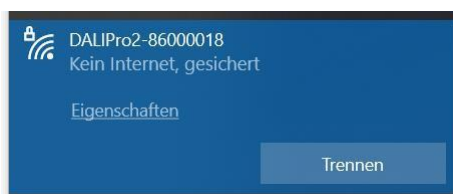

When connected to the local WLAN, the DALI PRO 2 IoT Controller will **always** have the IP address 192.168.8.1.

Connection to Wi-Fi via QR code

You can alternatively connect to the controller by scanning the QR code printed on the DALI Pro 2 IoT.

Your smart device then connects to the internal Wi-Fi network, provides the network key i.e. password and opens the browser-based commissioning interface in the default browser.

2.2 Registration process

When you connect to the Controller for the first time, you will be asked to create an account, by providing a username, email address and password. Furthermore, you can provide a name for the controller, set the user language as well as the date and time.

Please tick the Terms and Conditions box to accept and press the create button.

2.3 Log on

To establish a connection to the DALI PRO 2 IoT, via the Web UI, follow these steps:

- Open a web browser on your device.
- Enter the IP address of the lighting controller into the address bar of the web browser and press Enter.

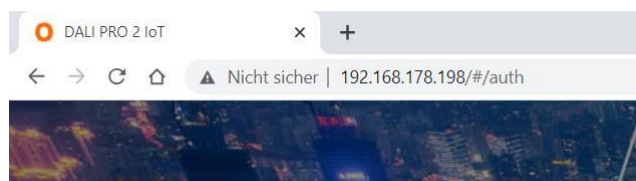

The web browser may display a warning message indicating that the connection is "Not secure." This is because the web browser does not recognize the device and no security-related information is stored. Please note that even though the connection is labelled as "Not secure," it is still safe to proceed, as long as you are connecting to the correct IP address of your lighting controller.

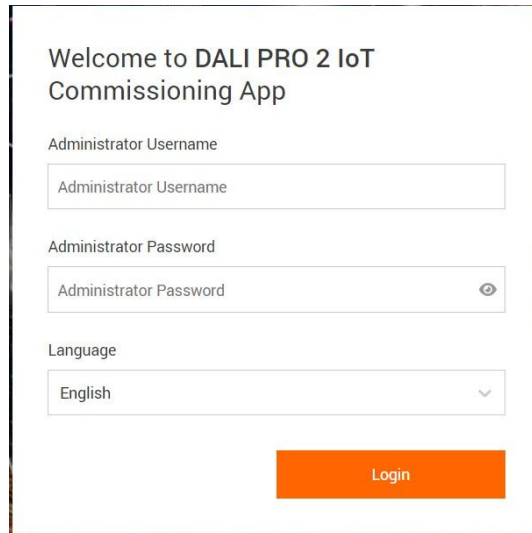

Welcome to DALI PRO 2 IoT
Commissioning App

Administrator Username

Administrator Password

Language

Login

On the login page of the graphical user interface, you are prompted to enter the administrator username and password. The username field is case insensitive, so you can enter it in either uppercase or lowercase letters.

- Enter the corresponding password for the administrator account.
- Click the "Login" button or press Enter to proceed.

You should now be connected to the graphical user interface of the lighting controller and can start using its features.

3. Controller configuration

The controller configuration is done in the following steps:

1. **Create a new project:** Begin by creating a new project for your configuration.
2. **Search for DALI devices:** Use the controller to search for DALI devices connected to the system.
3. **Select a template:** Choose a template that matches your desired configuration or design.
4. **Assign DALI devices to template functions:** Assign the DALI devices to their respective functions within the chosen template. This step ensures that each device operates according to its intended purpose in the configuration.
5. **Upload the project:** Once all the necessary assignments and configurations are complete, upload the project to the controller or the system to make it operational.

3.1 Project creation

To create a new project, click on the "Create a new project" button.

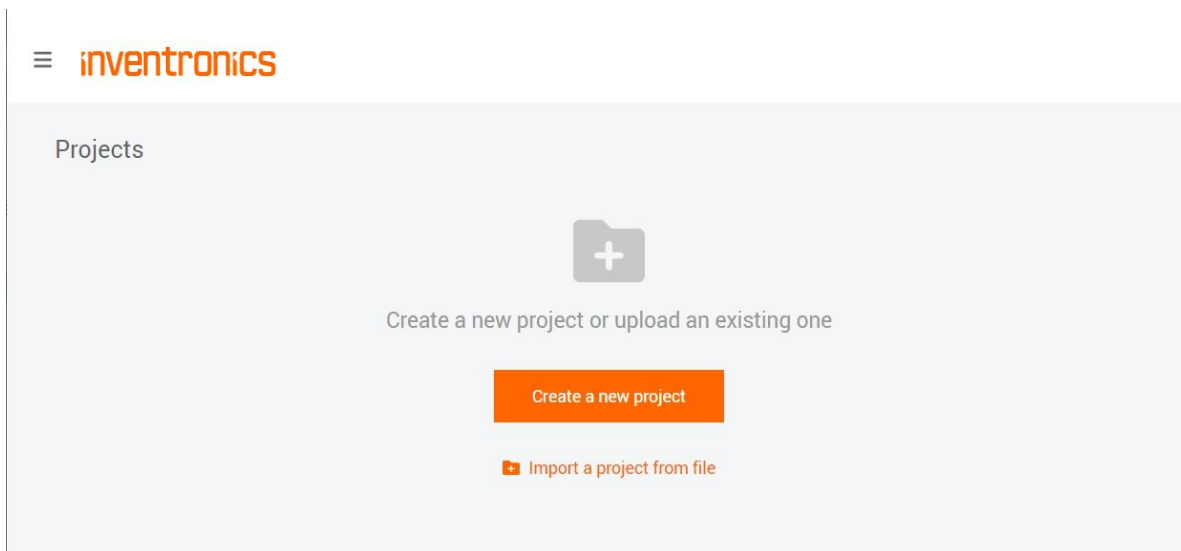

Provide a project name in the designated field (2). You can add additional information that helps describe and identify the project.

After entering the project name, the system will by default start scanning the network searching for DALI devices. (3)

Create a new project

Project name*

Demo Project

Additional information

Address,contact info, etc. (Optional)

Start DALI device search after creating the project

Cancel Create

3.2 Search for DALI devices

The system will automatically start searching for DALI devices and display the progress of the search in the indicator, located at the top-right corner of the interface.

Once the device search is completed, the search results will be shown, listing the DALI devices that have been discovered (1).

Read ECG data (1/4)

Searching Completed

Total found 12 devices

0 EL-T 4 2 4 2

Luminaire B24	B 24
Luminaire B23	B 23
Luminaire B22	B 22
Luminaire B21	B 21
S2.Presence	B 41
S1.Presence	B 26
S2.Light sensor	B 41

Start Searching

Through the "Start Searching" button (2), you can initiate a new DALI device search.

3.3 Template selection

In order to enable a simple, yet basic, controller commissioning, the WebUI allows for a template based commissioning. There are 15 different templates (e.g. General room, Meeting room, Class room etc.), each containing the base configuration for a certain type of application in terms of central function, zones, sensors & push button support etc.

The templates available on the device are displayed on the right side in a list. By clicking on the icon (3), you can access a brief description of the template.

Class Room
✕



- Teacher
- Row A
- Row B
- Row C

Central Function

[motion-sensor](#)

When motion-sensors are triggered, all lights in the classroom turn-on.

When motion-sensors are not triggered for 30 minutes, all lights in the classroom dim down and turn-off.

Teacher

[light-sensor](#)

Light-levels at the teacher area are regulated by the light-sensor for daylight harvesting.

Use of push-buttons deactivates the light-sensor regulation until the next OFF-ON cycle.

[push-button](#)

User can control the lights at the teacher area by push-buttons. Functionalities: ON/OFF/DIM.

Row A-C

[light-sensor](#)

Additional templates can be loaded onto the device using the "Import templates" function (1). These templates are created using the PC tool after the corresponding permissions have been granted.

The left area, also called **Manager Area**, represents the current project. Using the mouse, you can drag and drop the desired templates from the list to the left area (2). Each dragged-in template represents a zone or room. A template can be used multiple times to create zones with the same structure.

It is not necessary to use all light groups or link all available input devices with actual devices. Multiple devices of the appropriate type can be linked to each device position (light groups, buttons, motion sensors, light sensors).

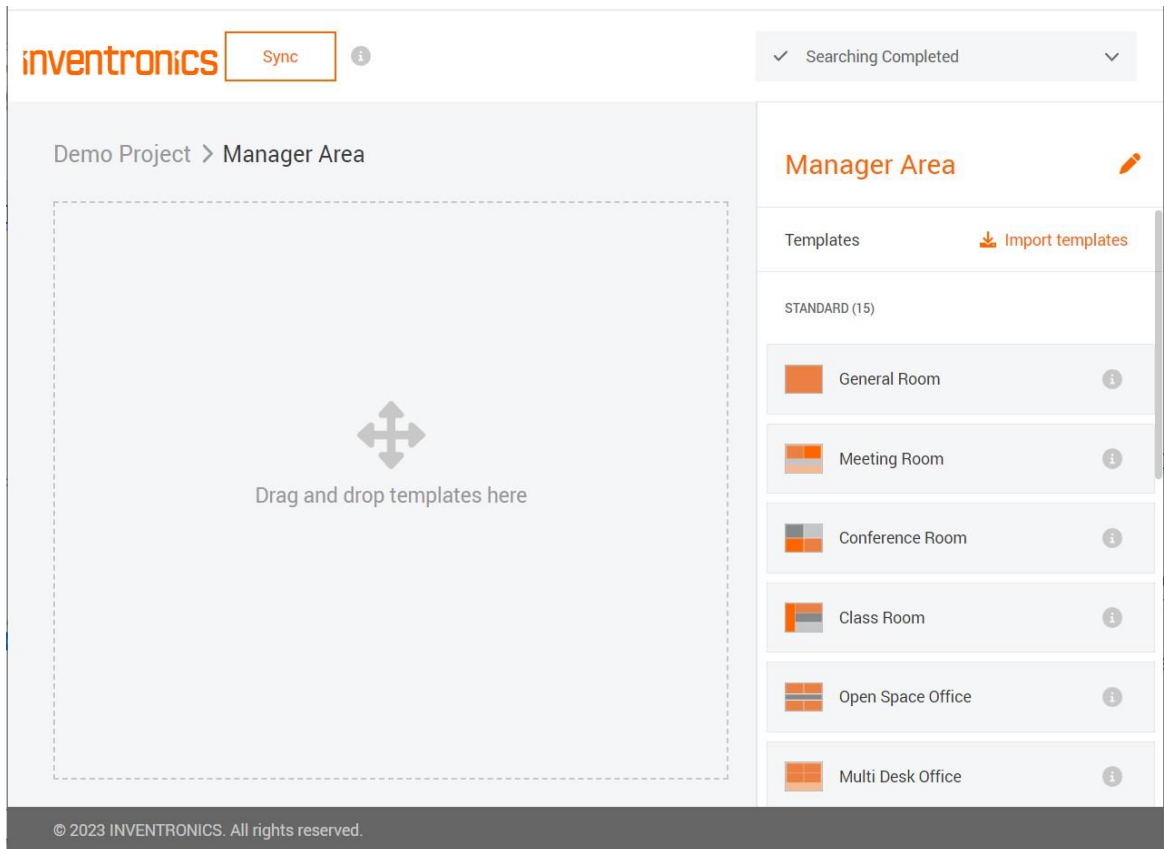

To further configure a room, simply click on the room within the Manager Area. You can now see the different zones included in that template, the associated devices and zone properties, in relation to linked sensors and push buttons. Clicking on the Tool icon (3) will allow you to make changes to the configuration options specific to that room.

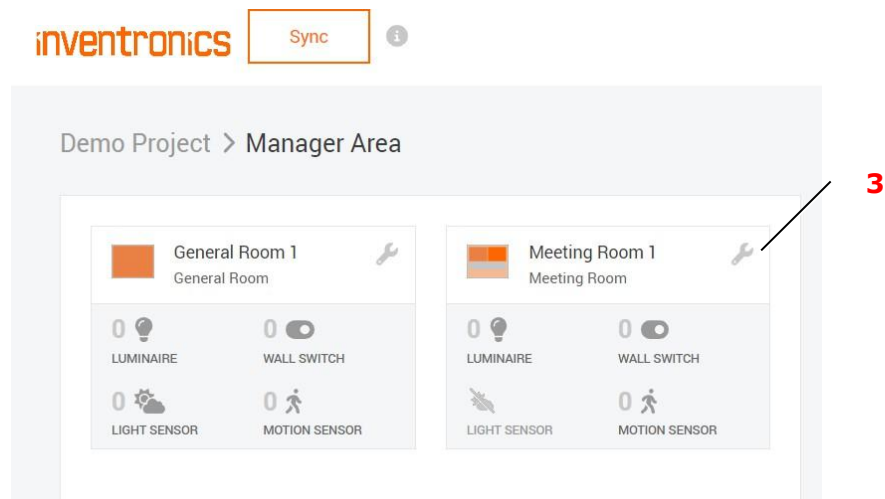

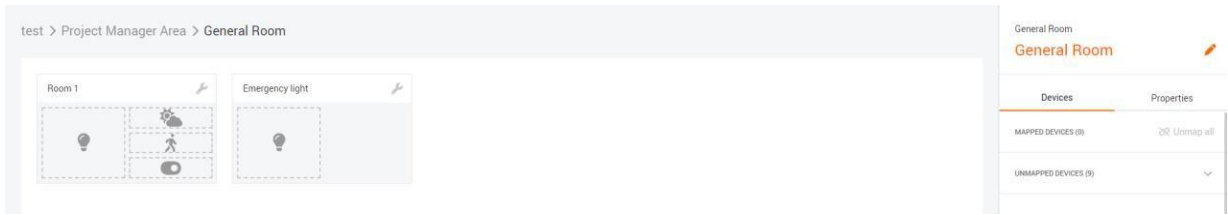

You can remove a room from the manager area by clicking on the Tool symbol (4). The delete zone button becomes in this case visible (5).

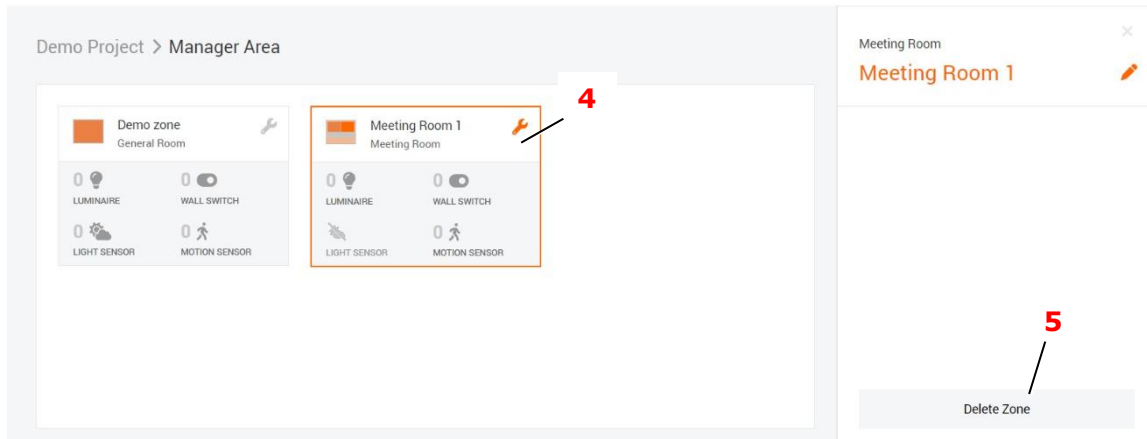

3.4 Assigning of DALI devices

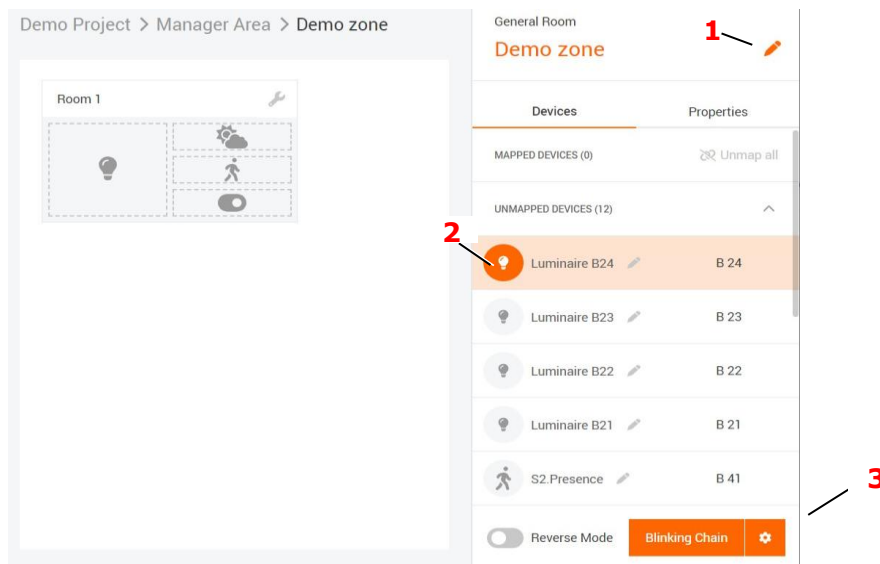

The room can be renamed by clicking on the icon (1).

By clicking on the lamp icon (2), an Electronic Control Gear (ECG) can be selected for blinking. The blinking will stop when the EVG is dragged and dropped onto the room, when another EVG is selected for blinking, or when, for example, the room symbol is clicked.

It is also possible to start a blinking sequence (3) for EVG localization. The EVGs from the list (all unused EVGs) will briefly light up one after another. The blinking sequence can be stopped by clicking on the icon (4) when the desired EVG lights up.

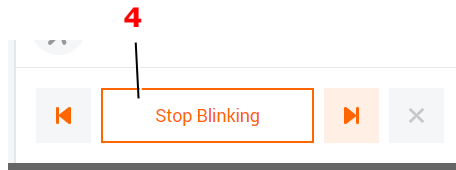

To assign an EVG to a room, it should be dragged into the room (5) until the room is highlighted in dark blue (6).

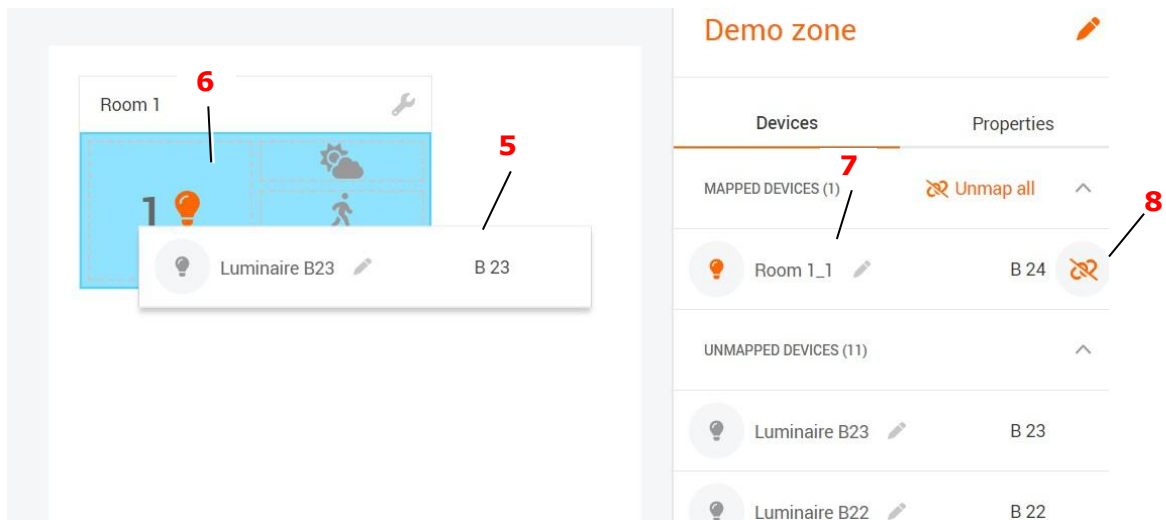

The EVGs assigned to the room will be displayed in a list called "Mapped Devices". An ECG can be removed from the room by clicking on the icon (8).

Input devices such as buttons and sensors can be identified using the "Reverse Blinking" function. This function can be activated by clicking on the "Reverse Mode" button (9), and it is possible to filter the search for different types of devices, like buttons or sensors (10).

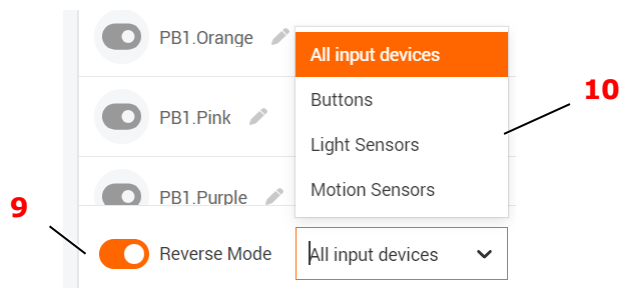

If, for example, a button is pressed, the corresponding entry in the list will be temporarily highlighted (11).

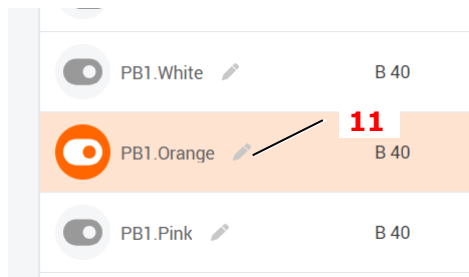

The input devices are dragged into the room, similar to the ECGs.

Some templates include a special "Zone Control" area (12). The input devices dragged into this area will affect more than one group.

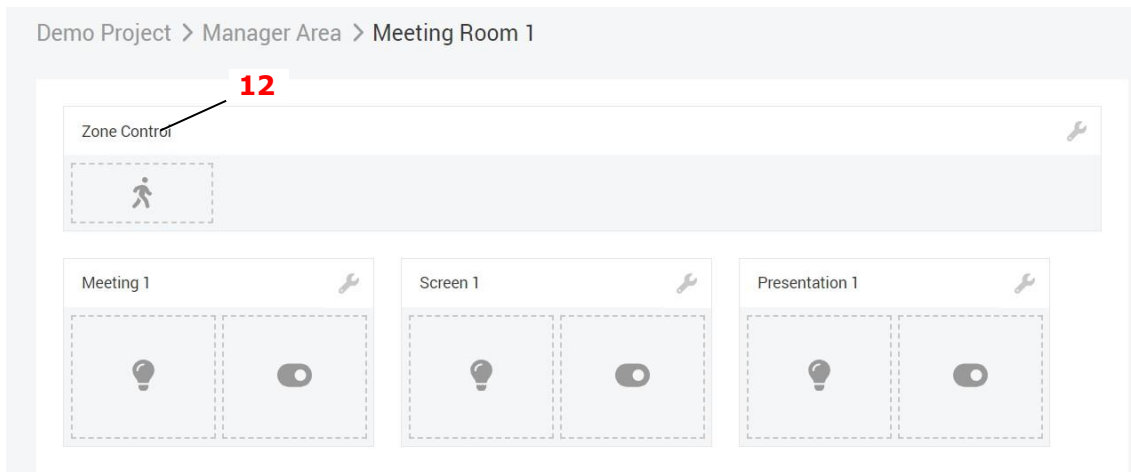

In the room view, the numbers of the respective assigned devices are displayed.

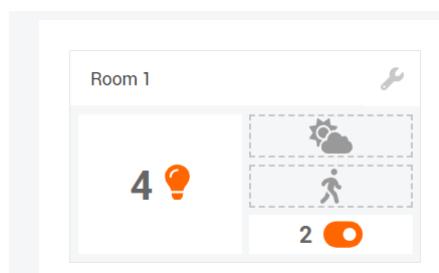

It is not necessary to assign a physical device to each input device type.

3.5 Upload a project

Once the configuration, including the assignment of DALI devices to various functions, is completed, the project can be uploaded to the lighting controller. This can be done by clicking on the "Sync" button (1).

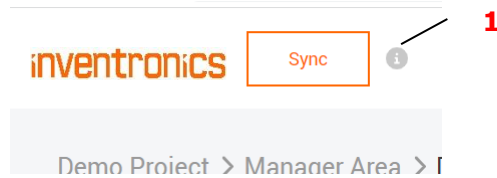

The uploading process may take some time, especially if there are multiple DALI devices connected, as each device needs to be individually configured through DALI communication. After the upload, the project will be displayed as the active project (2) on the lighting controller.

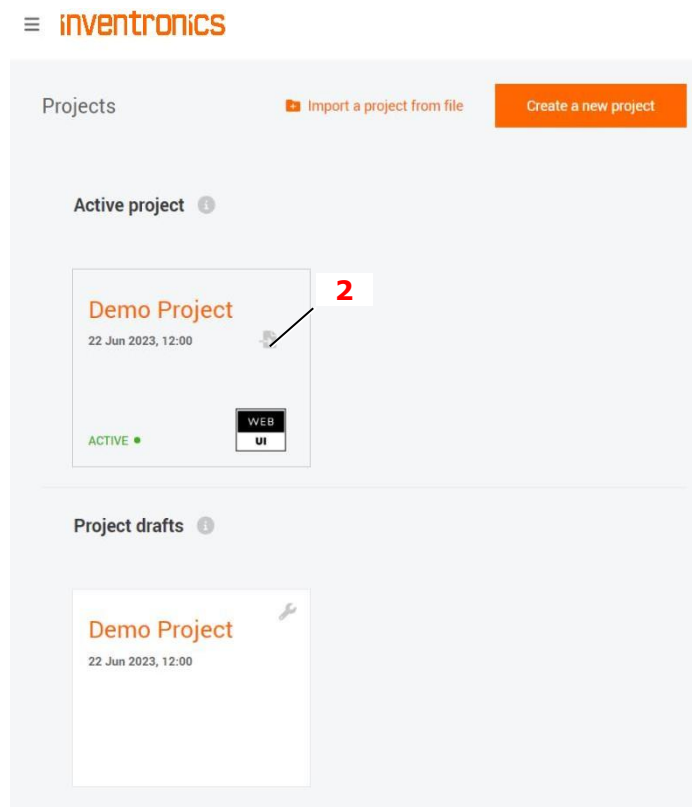

In the example, the project file "Demo Project" can be reopened and further edited to make changes. These changes can then be uploaded again with the modified configuration.

It's important to note that once further edits are made, the "Demo Project" file will no longer correspond to the active project on the lighting controller.

To make configuration changes based on the active project again, a copy of the active project can be created by clicking on the icon (3).

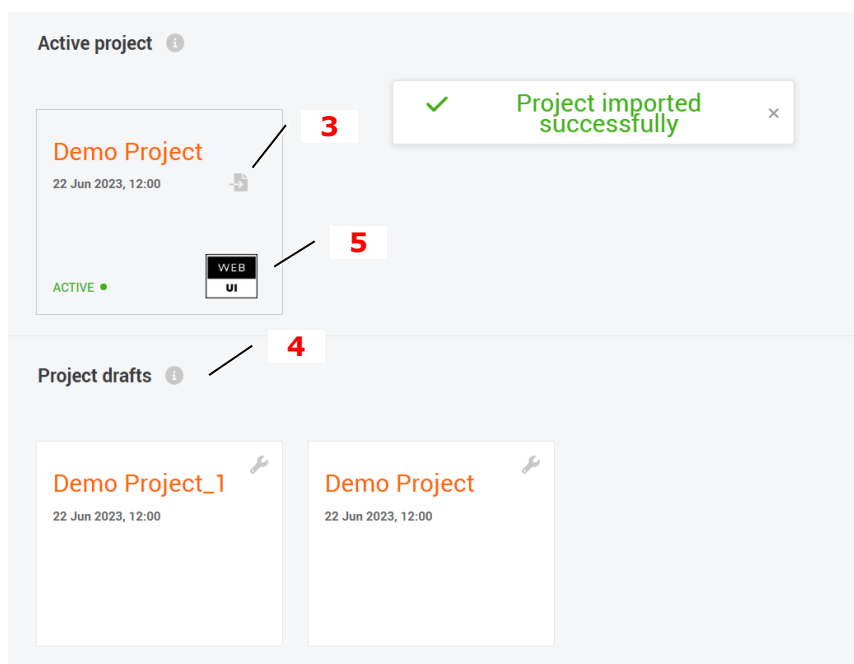

The copied project will appear in the *Project drafts* section (4).

The active project is indicated by an icon (5), which shows whether the project can be edited using the WebUI or if the last upload was performed using the PC tool. If the project was uploaded using the PC tool, it cannot be copied for further editing in the WebUI.

By clicking on the tool symbol in a project (6), additional functions will be visible on the right side. For example, to try out a variant, a copy can be created from a project file (7).

To edit the project file with the PC tool, it can be exported using the button (8). After editing, it can be imported again using the button (9). Please note that the original project file was created with this DALI PRO 2 IoT Controller and that the edited project file remains compatible with the WebUI.

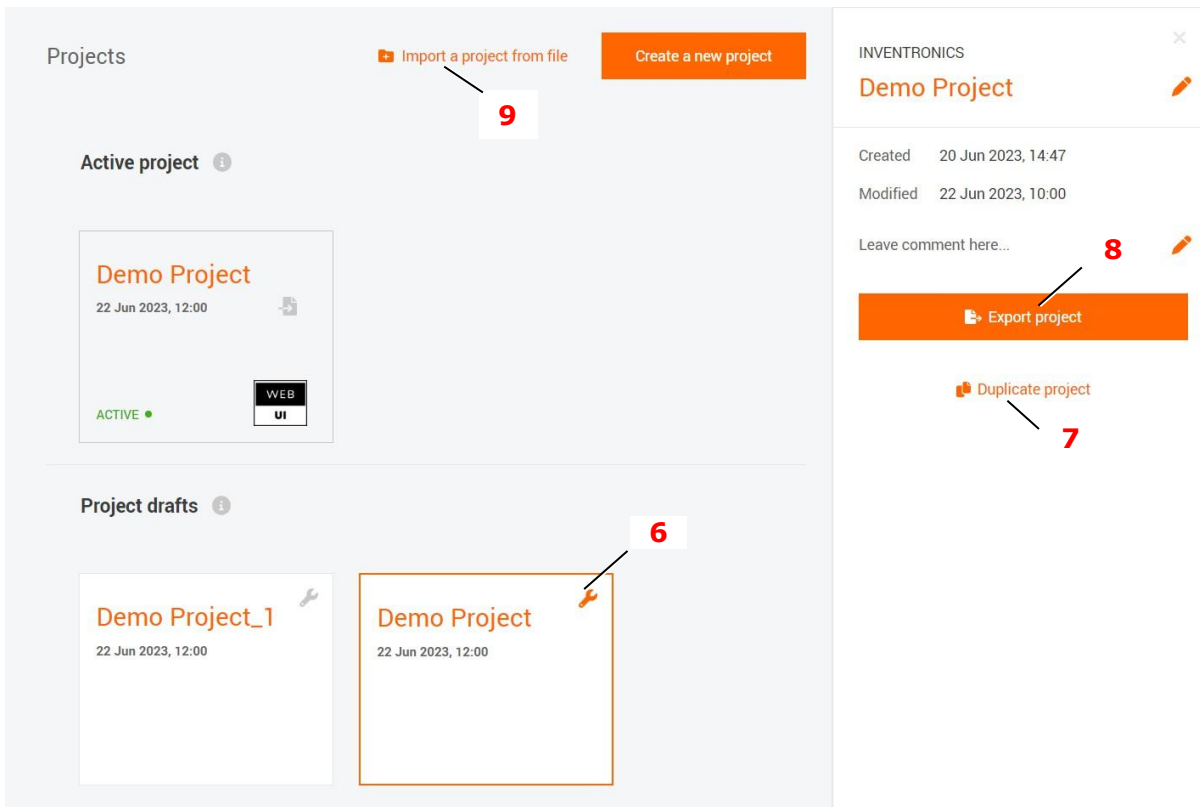

4. System Information

The system information displays the current firmware version number (1) and the serial number of the device.

You can also retrieve a complete list of firmware components, which will be saved as a text file (2).

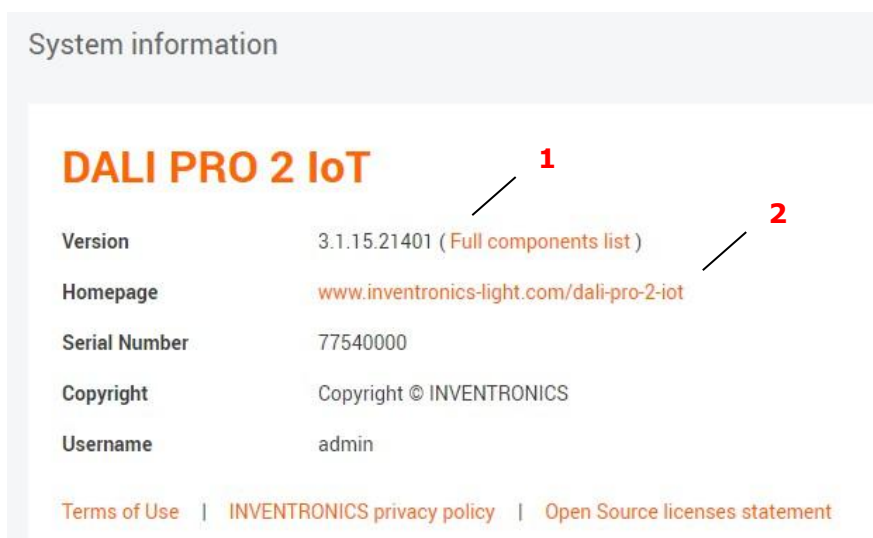

We recommend visiting our website https://www.inventronics-light.com/dali-pro-2-iot#firmware_updates to make sure that your device is using the latest firmware version. In case it's not, please follow the instructions included in the [Advanced](#) section of this document.

5. System settings

The *System settings* page allows you to edit the name and other information about the system.

5.1 General tab

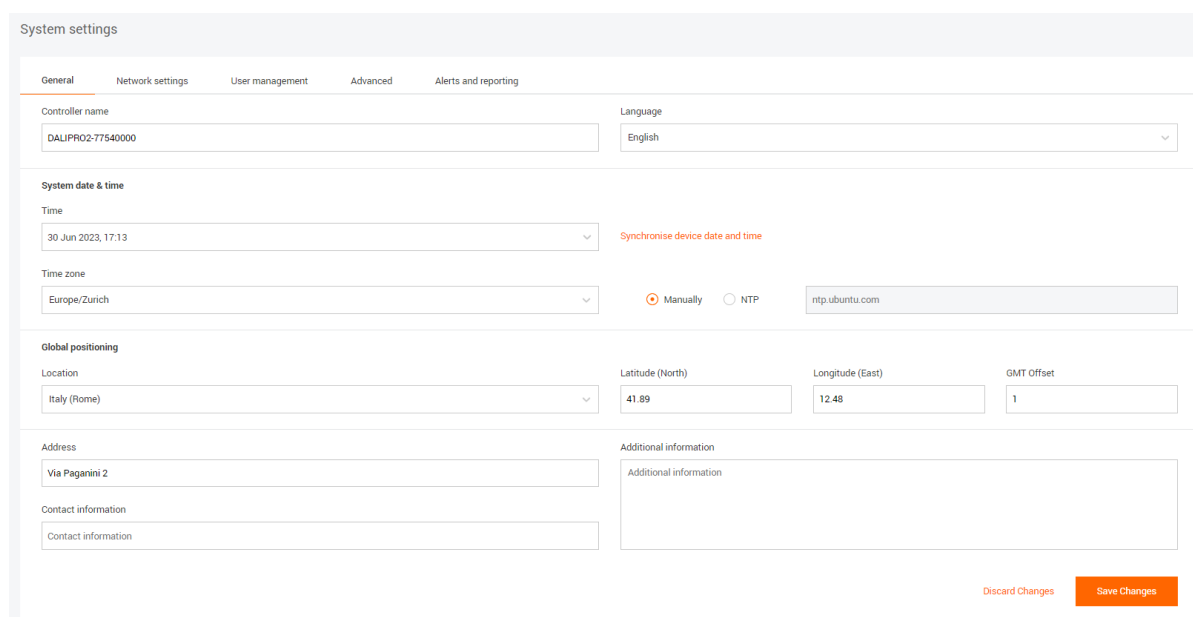

The screenshot shows the 'System settings' page with the 'General' tab selected. The page is divided into several sections:

- General:** Controller name (DALIPRO2-77540000), Language (English).
- System date & time:** Time (30 Jun 2023, 17:13), Time zone (Europe/Zurich), Synchronise device date and time (Manually selected), NTP (ntp.ubuntu.com).
- Global positioning:** Location (Italy (Rome)), Latitude (North) (41.89), Longitude (East) (12.48), GMT Offset (1).
- Address:** Address (Via Paganini 2), Contact information (Contact information).
- Additional information:** Additional information (empty text area).

At the bottom right, there are two buttons: 'Discard Changes' and 'Save Changes'.

Here you can set following info:

1. Controller name
2. Language
3. System date & time
4. Location (GPS and Address)
5. Contact information
6. Additional information

5.2 Network Settings

There are two elements in this section:

- **Ethernet**

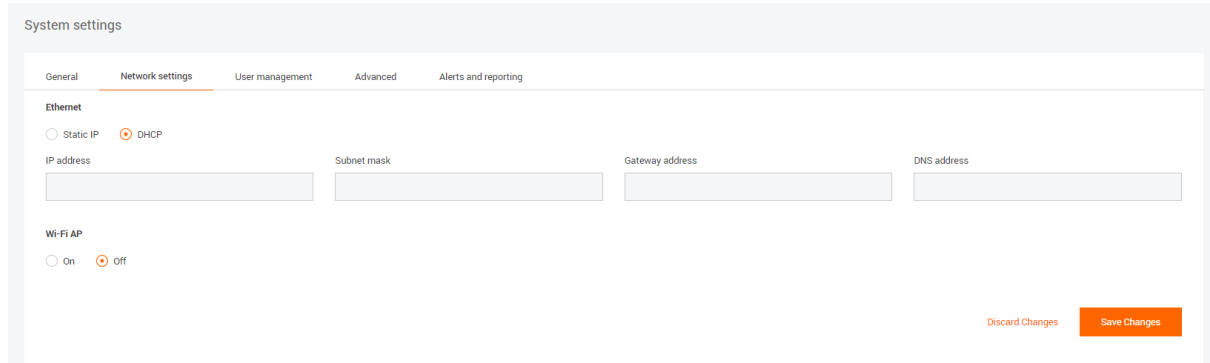

There are two different methods of assigning an IP address to the Controller:

1. **Static IP Address:** You can manually configure a static IP address, which then remains unchanged unless it is manually updated. With a static IP address, the Controller always uses the same IP address each time it connects to the network. We recommend using this setting.
2. **DHCP Address:** DHCP is a network protocol that automatically assigns IP addresses to devices on a network. The assigned IP address is typically temporary and subject to change if the device disconnects from the network or the DHCP lease expires. DHCP is commonly used for devices like computers, smartphones, and tablets that do not require a fixed IP address and can dynamically obtain one from the network.

- **Wi-Fi AP**

You can enable and disable the controller’s Wi-Fi access point, to connect to it wirelessly, by clicking on the respective On or Off button. This functionality is also possible by clicking on the relevant Wi-Fi button on the controller.

5.3 User Management

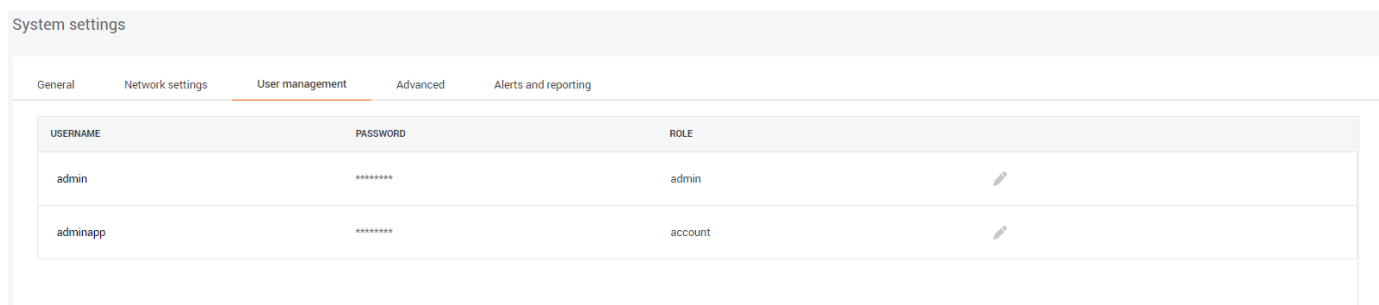

Here you can view the different users registered and change the password.

5.4 Advanced

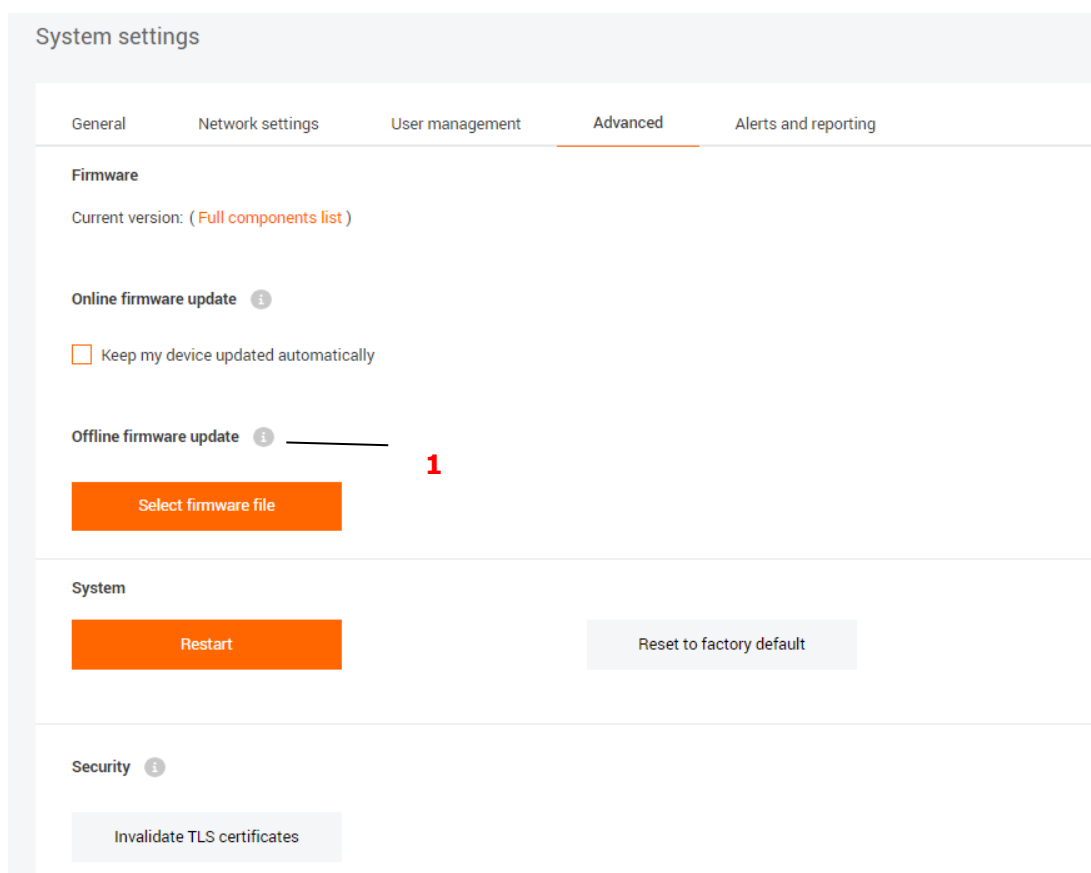

In this section you can:

1. See the current Firmware (FW) version
2. **Online firmware update:** If connected to the Internet, the Controller can automatically receive updates from the online inventronics firmware store. Automatic updates can be disabled by unchecking the related option in this menu. **NOTE:** do not enable this option if you have installed on your system test or preview updates, as they will be removed and the official packages reinstalled.
3. **Offline firmware update:** The device firmware can be updated using the upgrade package available on https://www.inventronics-light.com/dali-pro-2-iot#firmware_updates. Simply download the Firmware package, store it in your PC and select it (1) to update your DALI PRO 2 IoT. You can easily bring your controller up to date by using the **DALI PRO 2 IoT update tool**, available on the same link!
4. **System:**
 - You can Restart the system by clicking on the orange Restart button
 - You can reset to the factory default settings by clicking on the respective text. In this case, a pop up window will prompt you to confirm your choice.

Reset to factory default

Are you sure you want to reset the system to factory default?

Cancel

Confirm

5. Security

By clicking on the Invalidate TLS certificates button all connected applications (mobile applications, PC software) will need to perform the login procedure again. Any LAN Interconnect configuration will need to be re-configured.

6. Feature keys

Certain applications, e.g. API or Emergency lighting, require a Feature key in order to be enabled. In this section we manage the introduction of the feature keys.

Feature keys ?

QWERTYUIOPasdfghjkl9876543221==

Apply key

Features status ?

Feature	Enabled
Emergency lighting	Yes
Cloud API	Yes

5.5 Alerts and Reporting

Once the Controller is connected to the internet, it can send out failure notifications for both DALI emergency lighting, as well as for general lighting devices (see [Emergency Lighting](#) and [Luminaire failure alerts](#) for a detailed error description).

System settings

General
Network settings
User management
Advanced
Alerts and reporting

Email recipient to manage subscriptions ⓘ

Current Recipient:

Enter eMail address

Change recipient

Delete recipient

Email recipients for notification/reports

Enter name

Enter eMail address

Fixture Alert [FA] ⓘ
 Emergency Lighting [EL] ⓘ

Add recipient

Name	eMail	FA	EL	
name	email	+	+	🗑

E-Mail report (Emergency Lighting) configuration

Configure shipment

Send report by e-Mail now

- **Email recipient to manage subscriptions:** Here you can enter the e-mail address of the person in charge for deleting people from the reports recipients e-mail list.
- **Email recipients for notification/reports:** Here you can enter the names and email addresses of the people who shall receive the notifications and the reports. You can chose to send only Emergency lighting (EL) notifications, only the Fixture Failure Notifications (FA) or both.
- **E-Mail report (EL) configuration:** Here you can configure the frequency (weekly, twice per month, once per month), with which the controller shall send out the EL reports.

6. Remote Access

The remote access service allows you to connect to your DALI PRO 2 IoT from anywhere in the world. To use this service, the DALI PRO 2 IoT must be connected to the Internet.

In order to use the remote access service on your DALI PRO, you first need to register a personal account by clicking the Create an account button (menu→ Remote access). Then, please type into the text box the registered email address and click the Activate service button.

Use a web-browser and type the following URL: <https://remote-access.dalipro.io>
The Log In screen will appear:

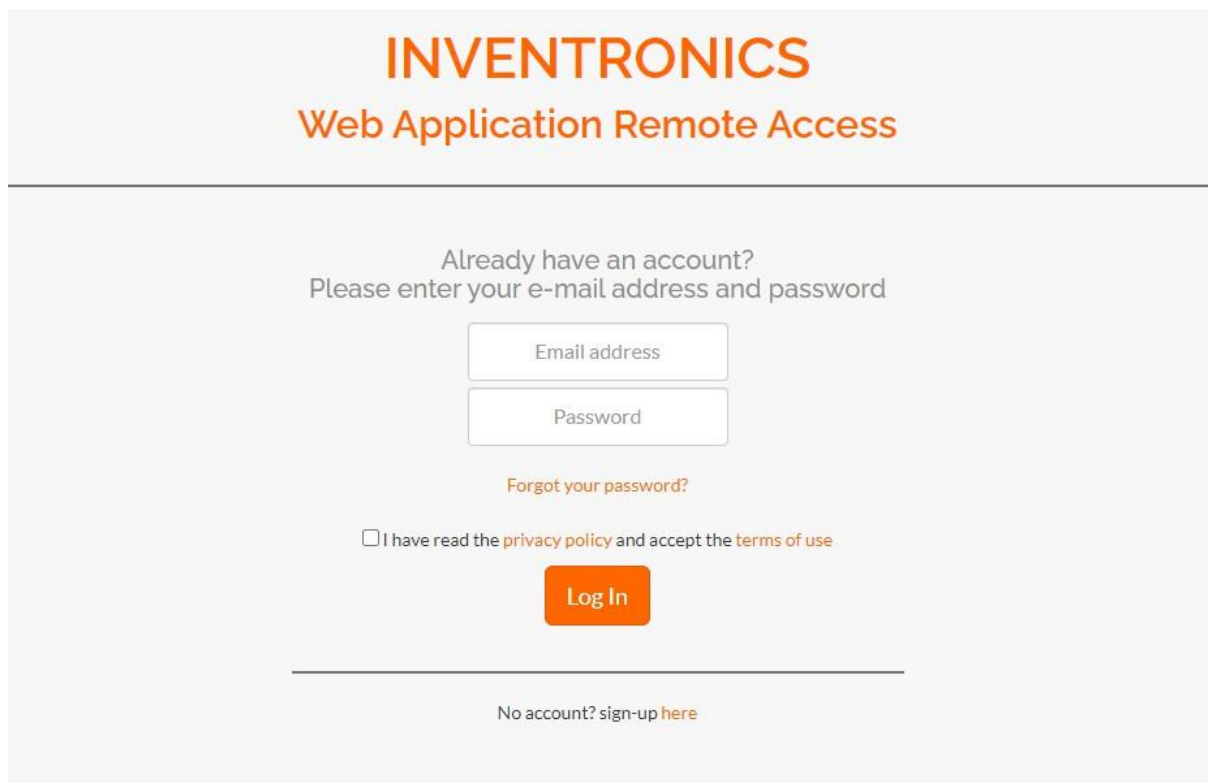

The screenshot shows the login interface for the INVENTRONICS Web Application Remote Access. At the top, the brand name 'INVENTRONICS' is displayed in large orange letters, with the subtitle 'Web Application Remote Access' below it. The main heading asks 'Already have an account?' and prompts the user to 'Please enter your e-mail address and password'. There are two input fields: 'Email address' and 'Password'. Below these fields is a link for 'Forgot your password?'. A checkbox is present with the text 'I have read the privacy policy and accept the terms of use'. A prominent orange 'Log In' button is centered below the checkbox. At the bottom, a horizontal line separates the login section from a link that says 'No account? sign-up here'.

If you do not have an account yet, please sign-up and follow the instructions.

If you already have an account, log in with your e-mail address and password and you will be re-directed to the start page.

You can check the dedicated Quick start guide available here: https://www.inventronics-light.com/dali-pro-2-iot#quick_start_guides

7. Emergency Lighting

The Emergency Lighting (EL) feature of the DALI PRO 2 IoT controller allows you to automatically test your DT1 emergency luminaires, it issues and emails an EL report at a user specified time interval and sends out alarm notifications in case of a detected failure.

The EL feature is available from firmware version 3.1.11.x or higher. The feature is preactivated and free for use for up to 5 EL luminaires per controller. If more EL luminaires are connected to a controller, these will not be visualized in the web UI EL page or in the issued report.

In order to receive reports for more EL luminaires, you need to unlock the full EL feature by means of a feature key to be purchased. Please contact your OEM or Inventronics sales representative and ask for it.

Please check the dedicated Quick start guide available here: https://www.inventronics-light.com/dali-pro-2-iot#quick_start_guides.

7.1 Commissioning

The emergency lighting devices are recognized after the device search and a new lighting group appears automatically in each room (zone), only for the emergency lighting devices.

This group has no functions and is dedicated to emergency lighting control gear (CG) without normal light functionality (type C and D). Only emergency lighting devices can be mapped to this special group.

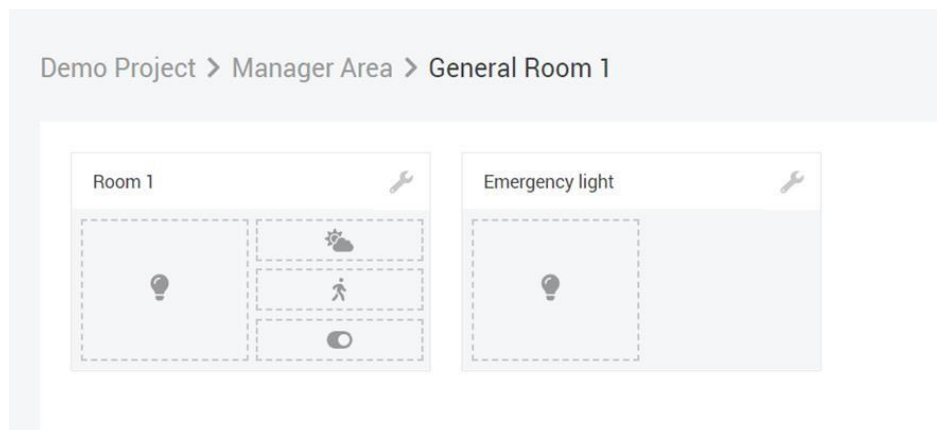

Please note that the zone assignment is important for the automatic test rules, as the test algorithm prevents more than one EL luminaire to be tested at the same time in the same zone.

7.2 Configuring the EL test reports

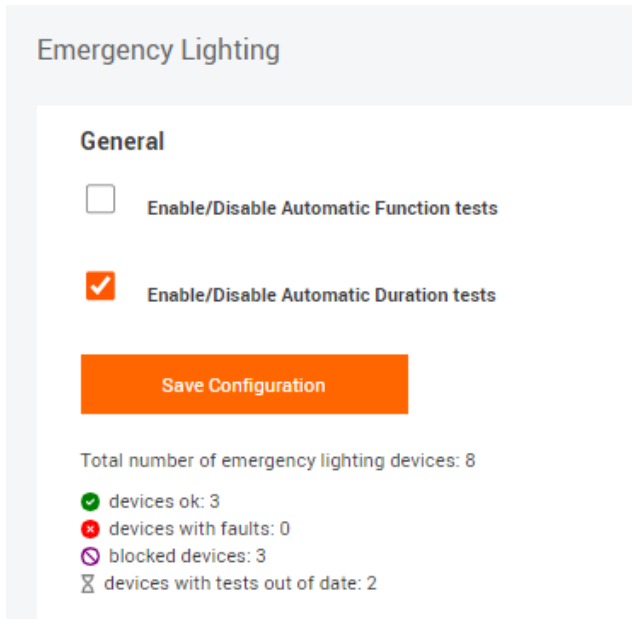

Log on to the controller and follow Menu> Emergency Lighting

In the General section you can disable the automatic function (enabled by default) and/or duration tests by ticking the respective box and saving the configuration.

In this section you see also the overview of the emergency lighting installation, including following information:

- Total number of EL devices
- Device status overview. The possible values are: OK, with faults, missing, blocked (because of locked feature), with tests out of date, devices under test.

7.3 EL report

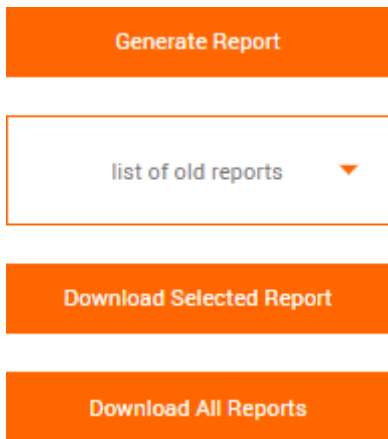

The user is able to generate a EL report, by pressing the relevant button.

Furthermore, the user can download old reports, either by clicking on the drop-down list and selecting an individual report to download, or by clicking on the "Download All Reports" button. The old reports are named after the issued date and either an [OK] or a [!], the former indicating that there were no errors or other issues with the EL installation detected at that point and the latter suggesting that faults were detected.

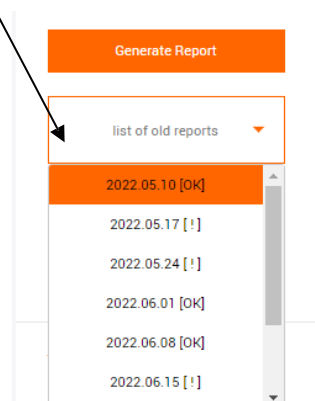

The EL report contains following information:

DALI PRO 2 IoT - Emergency Lighting Report

Control unit: DALIPRO2-77540000 Date: 2022-07-11 11:59:48 AM
 Serial number: 77540000 Devices: 8

Title/Area/Zone	State	Battery	Function Test	Duration Test	Info
Emergency light 1 D <small>Office Area/Single office</small>	● Normal	100%	● Completed <small>2022.07.08 16:57:54</small>	● Completed <small>2022.07.08 20:45:37</small>	180 min None
Emergency light 2 B <small>Office Area/Single office</small>	● Normal	100%	● Completed <small>2022.07.08 16:56:29</small>	● Completed <small>2022.07.08 20:06:17</small>	180 min None
Emergency light 3 B <small>Office Area/Open Office</small>	● Normal	100%	● Completed <small>2022.07.08 16:56:41</small>	● Completed <small>2022.07.08 20:06:29</small>	180 min None
Emergency light 4 D <small>Office Area/Open Office</small>	● Normal	100%	● Completed <small>2022.07.08 16:56:53</small>	● Completed <small>2022.07.08 20:44:48</small>	180 min None
Emergency light 5 B <small>Office Area/Corridor</small>	● Normal	100%	● Completed <small>2022.07.08 16:57:05</small>	● Completed <small>2022.07.08 20:06:41</small>	180 min None
Emergency light 6 D <small>Office Area/Open Office</small>	● Normal	100%	● Completed <small>2022.07.08 16:57:18</small>	● Completed <small>2022.07.08 20:45:00</small>	180 min None
Emergency light 7 D <small>Office Area/Open Office</small>	● Normal	100%	● Completed <small>2022.07.08 16:57:30</small>	● Completed <small>2022.07.08 20:45:13</small>	180 min None
Emergency light 8 D <small>Office Area/Corridor</small>	● Normal	100%	● Completed <small>2022.07.08 16:57:42</small>	● Completed <small>2022.07.08 20:45:25</small>	180 min None

N/A = Not Available

Report Header:

Control unit name and S/N, date of the report and number of EL devices.

Report Body:

- Device name, Area and Zone.
- The device state. Following values are possible: Blocked (the feature is locked and the device over the free limit), device not available (no DALI response), Inhibit (Inhibit mode activated on the device, preventing it to go into emergency mode after power interruption), Test in Progress, Fault (the last function test failed), Test out of date, Normal.
- The battery level.
- The function test status. Following values are possible: Completed (incl. date of last test info), Tests out of date, Test in progress, Fixture fault, N/A (when a device is not available).
- The duration test status. Following values are possible: Completed (incl. date of last test info), Tests out of date, Test in progress, Fixture fault, N/A (when a device is not available). The report also displays the minutes it took for the last test to be completed.
- Information regarding faults detected: Circuit Fault, Battery Duration Fault, Battery Fault, Lamp Fault, Battery Level Unknown.

7.4 Test configuration

In this section the frequency of the automatic tests, for both function and duration tests, can be set. It is also possible to define the time slot (in hours: minutes) during which, the duration test shall be performed; the possible values are in the range 0:00-23:59.

The default values are: Once per month for the function test and Once per Year for the Duration test.

Test Configuration ⓘ

Function Tests

Once per Month Twice per Month Weekly Daily

Duration Tests

Once per Year Twice per Year Quarterly Monthly

Time Window Test Start (hh:mm) Time Window Test End (hh:mm)

7.5 Email configuration

Please see section [Alerts and Reporting](#)

8. Luminaire failure alerts

The Luminaire Failure Alert feature in DALI PRO 2 IoT provides notifications for three types of failures, allowing for quick identification and resolution. These are given in the form of a summary table, that includes info on the device name, DALI line and address, zone, serial number, GTIN and the failure type. Furthermore, if the controllers is connected to the internet, Email notifications can be sent out the moment a failure has been diagnosed (see [Alerts and Reporting](#))

Luminaire failure alerts

Refresh information

Summary table

Title	DALI line	Address	GTIN	Zone	Serial number	Luminaire failure type
Luminaire B01	1	0	5060203772239		1858018228	Device is not responding
Luminaire B02	1	1	9006210340968		694698497	Device is not responding
Luminaire B04	1	3	9006210340968		694698497	Device is not responding
Luminaire B05	1	4	4008321964403		690769920	Device is not responding
Luminaire B06	1	5	5060203772239		1858018339	Device is not responding
Luminaire B07	1	6	9006210340968		694698497	Device is not responding
Ballast 1_2	1	7	5060203772239	General Room	1858018489	Device is not responding
Ballast 1_3	1	8	5060203771768	General Room	2932354413	Device is not responding
Ballast 1_1	1	11	5060203772239	General Room	1858018439	Device is not responding

Possible failure types

Device is not responding	The device could be either powered off, or have been removed, or not acknowledging DALI commands.
Driver failure	The luminaire is not working due to a driver failure. A driver replacement is needed.
Light source failure	The luminaire is not working due to a light source failure. A replacement of the light source or the complete luminaire is needed.

1. Device Not Responding:

This alert indicates that the device connected to the DALI network is not responding. It could be due to the device being powered off, physically removed, or not acknowledging DALI commands. Troubleshooting steps may involve checking the power supply, reconnecting the device, or verifying the DALI connection.

2. Driver Failure:

If a luminaire is not functioning properly due to a driver failure, this alert will be triggered, indicating that the driver has encountered an issue. To resolve this, a driver replacement is required to restore the luminaire's operation. The GTIN information provided in the table helps identify the exact driver type.

3. Light Source Failure:

This alert is triggered when the luminaire is not working due to a failure in the light source itself. It suggests that either the light source within the luminaire needs to be replaced or, in some cases, the entire luminaire may require replacement.

By providing specific alerts for these three types of DALI failures, the Luminaire Failure Alert feature assists users and maintenance personnel in quickly diagnosing the issue and taking appropriate action. It helps ensure optimal functionality and performance of the lighting system.

9. Notes



If an error message like that appears, it's an indication that the login validity has likely expired. The best course of action is to enter the IP address again in a new browser window. This will initiate a new session with a fresh login.

10. Technical Data

Safety Standards	EN62368-1, EN 60529	
	International Protection Basic insulation	IP 20
EMC Standards	EN 55024/EN550032 EN 301 489-1 V2.1.1 EN 301 489-17 V3.1.1	Class A
DALI Standards	IEC 62386-101, -103 Voltage Current Addresses	DALI 2 certified 16V nominal 250mA maximum 2 x 64
Environment	Ambient temperature, operating Ambient temperature, storage Relative Humidity, non- condensing Application	0 to +40°C -25 to +85°C 5 to 93% indoor
Mechanical Data	Dimensions Mounting Weight Housing material	107 x 91 x 62mm 6 units, 35 mm DIN rail 247 grams Plastic, ABS-PC
	Cable connection, stiff Cable connection, flexible Wire peeling length	0,5 to 2.5mm ² 0,5 to 1.5mm ² 10 to 12mm
Power Supply	Built in Input voltage Input Power	220 - 240V ~ / 50/60 Hz 20W
Data Ports	LAN for PCTOOL/Remote access USB for WIFI dongle (included) Micro USB for flashing firmware	100Mb/s EW-7811Un manufacturer only

INVENTRONICS GmbH

Parking 31-33
85748 Garching, Germany
Phone +49 89 6213-0
www.inventronics-light.com

inventronics